

The Olis[®] Hummingbird Series



Tiny. Fast. Precise.

Used in all new Absorbance, Fluorescence, and Circular Dichroism Spectrophotometers

Hand-Made Alternatives to Mass-Marketed Appliances
Tiny, fast, precise, and built for you.

The Olis Hummingbird was introduced in October, 2005. This all-new monochromator earned its name, the 'Hummingbird,' for its small size and high precision. Its acquisition rate can reach 20 MHz (20,000,000 readings per second). Its precision is effectively perfect.

Developed initially for laser photolysis absorbance and quickly recognized as perfect for UV CD, the Hummingbird was first used in a scanning spectrofluorimeter in February 2006. Raman, ORD, LD, and other types of spectrometers will follow.

The Olis Hummingbird systems are each made by hand. Every component is of the highest quality. There are no plastic or breakable components. The mirrors and gratings are cemented in position within the 0.65 cm thick cast aluminum plate chassis. All electronics are housed in a separate control box for easy access during diagnose or repair.

The Olis SpectralWorks control software is far more useful and comprehensive than what typical instrument manufacturers provide: It is the power behind the electronic simplicity, reliability, and modularity of Olis instruments. And, the Olis software is behind the instantaneous data presentation and analysis power.

Optics of the Olis Hummingbird Monochromator

All Hummingbird monochromators can be optimized for one spectral range or more. Notice that different detectors are required as one moves from UV/Vis to NIR. Also, exchange of gratings and a drop-in filter for second order light rejection are necessary when changing from UV/Vis to NIR. To learn more about gratings, visit <http://www.newport.com/Grating-Physics/383720/1033/catalog.aspx> (or just Google "oriel gratings").

GRATINGS	SPECTRAL RANGE	WAVELENGTH RESOLUTION	TYPICAL APPLICATIONS	DETECTORS
<p>The gratings determine the spectral range and wavelength resolution.</p> <p>Common choices are:</p>	<p>The spectral range is fixed by the gratings. Gratings in the Olis Hummingbird monochromator can be changed with minimal effort.</p>	<p>The bandpass sets spectral resolution, which is fixed by the number of lines on the gratings (the grating's dispersion) times the slit width. The dispersion is fixed; the slit widths are generally 0.5 or 2 nm, but can be 0.28, 0.60, 0.76, 1.24, 1.56, 3.62, or a custom-manufactured one.</p>	<p>Secondary structure determination (CD) mandates first grating pair (typical range for a protein CD spectrum is 260-190 nm).</p>	<p>Photomultiplier tubes, PMTs, are useful from UV to around 850 nm. InGaAs detectors are useful from ~600-1650 nm or ~800-2600 nm (extended range). Photon counting detectors, PCM, are used for maximum sensitivity in fluorescence.</p>
<p>1200 lines/mm; blazed at 250 nm</p>	<p>170 - 700 nm</p>	<p>4 nm/mm x 0.12 mm = 0.5 nm resolution</p> <p>4 nm/mm x 0.5 mm = 2 nm resolution</p>	<p>CD: Secondary protein structure determination (typically 260-190 nm) and tertiary structure information. Absorbance and Fluorescence: UV-shifted UV/Vis</p>	<p>Photomultiplier tubes (PMTs)</p>
<p>1200 lines/mm; blazed at 350 nm</p>	<p>250-800 nm</p>	<p>4 nm/mm x 0.12 mm = 0.5 nm resolution</p> <p>4 nm/mm x 0.5 mm = 2 nm resolution</p>	<p>Absorbance and Fluorescence: Visible-shifted UV/Vis; CD, excluding the secondary structure determination region for proteins.</p>	<p>PMTs or Photon counting detectors, PCM</p>
<p>800 lines/mm; blazed at 600 nm</p>	<p>350-1200 nm</p>	<p>6 nm/mm x 0.12 mm = 0.7 nm resolution</p> <p>6 nm/mm x 0.5 mm = 3 nm resolution</p>	<p>Absorbance, Fluorescence, and CD, Visible to near NIR Nanostructures, Polymers, Metal ion chelation</p>	<p>PMTs and InGaAs, and/or PCM</p>
<p>600 lines/mm; blazed at 750 nm</p>	<p>400-1650 nm</p>	<p>8 nm/mm x 0.12 mm = 1 nm resolution</p> <p>8 nm/mm x 0.5 mm = 4 nm resolution</p>	<p>Absorbance, Fluorescence, and CD: Visible to near NIR Nanostructures, Polymers, Metal ion chelation</p>	<p>PMTs and InGaAs, and/or PCM</p>
<p>300 lines/mm for NIR use.</p>	<p>800-3200 nm (detection limit of InGaAs is 2500 nm)</p>		<p>Absorbance, Fluorescence, and CD: Visible to extended range NIR Nanostructures, Polymers, Metal ion chelation</p>	<p>Extended Range InGaAs</p>

1. The Hummingbird comes standard with manually insertable slits (see Oriel's 77394 Fixed Slit Holder). However, at modest additional cost, the monochromator can be fitted with a variable slit width mechanism, which lets one 'dial in' a slit width, rather than pull out and replace slits (see Oriel's 77269). The Olis machine shop can custom-cut any slit width, should Oriel not carry the perfect slit width for your application.

Absorbance, Fluorescence, and CD Models

Variations on these primary designs can be made by you or us

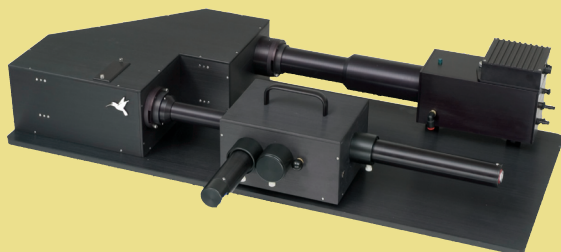

**Olis DB 620 UV/Vis NIR
Spectrophotometer**

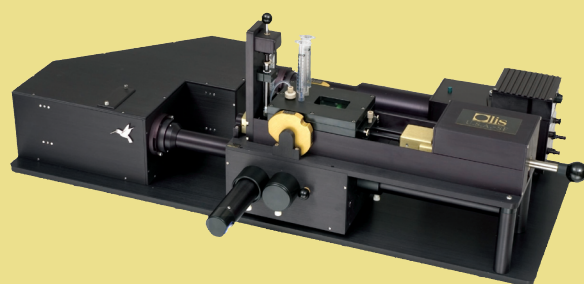

**Olis DB 620 UV/Vis NIR
with Stopped-Flow**



**Olis DSM 20 CD
Spectrophotometer**

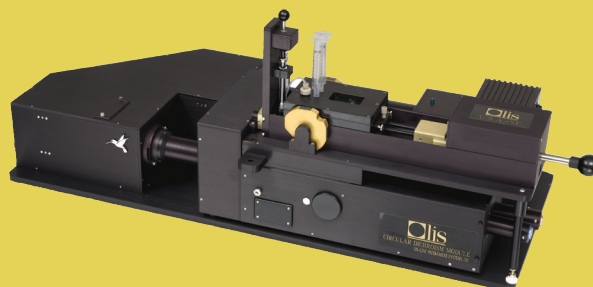

**Olis DSM 20 CD
with Stopped-Flow**

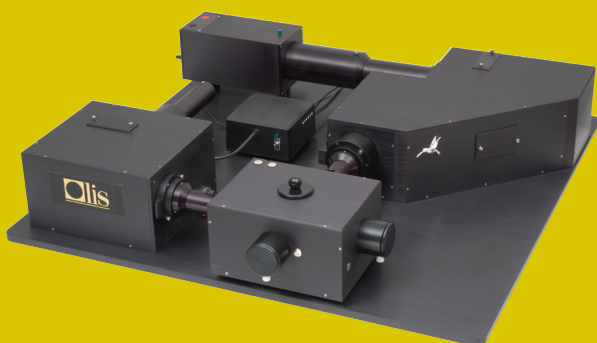

**Olis DM 245
Spectrofluorimeter**

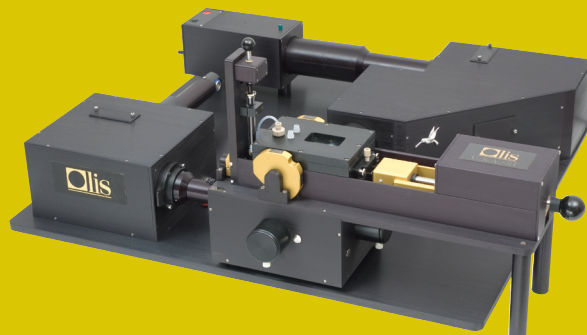

**Olis DM 245
with Stopped-Flow**

First RMS Numbers on the Olis DB 620

Even lower noise accompanies use of a 150 watt xenon arc rather than the default choice 75 watt xenon arc

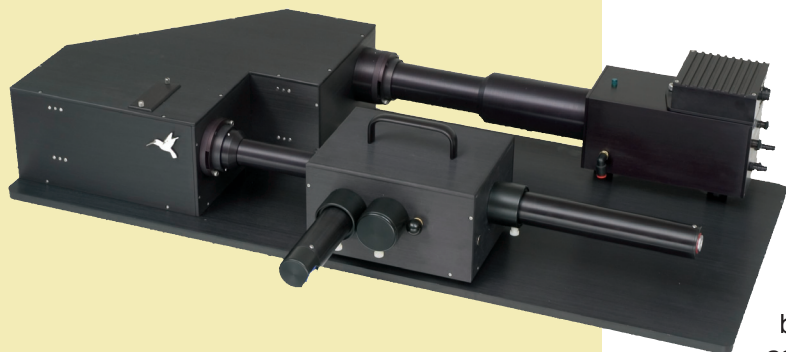

No processing of the data was done to achieve the following RMS noise levels. The data are literally “raw”: no averaging, no filtering, no smoothing. In each case, 1000 points were collected in the allotted time and these were fitted to a straight line with the root mean square (RMS) calculated.

Collection Time (seconds)	Wavelength (nm)	RMS Noise (AU)
0.001	250	0.0014
0.001	350	0.00037
0.001	450	0.00030
0.001	550	0.00036
0.01	250	0.00079
0.01	350	0.00022
0.01	450	0.00016
0.01	550	0.00018
0.1	250	0.00028
0.1	550	0.00007
0.5	250	0.00017
0.5	550	0.00005
1.0	250	0.00016
1.0	550	0.00005

Standard Performance Values for Olis DB 620

TIME PER DATUM= 0.01 seconds to arbitrarily long
SCAN RATE with 0.01 second integration time is ~140 nm/minute

; 200 points over 50 nm span, ~ 20 seconds

; 100 points over 50 nm span, ~ 10 seconds

SCAN RATE with 1.0 second integration time and 0.25 nm/step is ~9.3 nm/minute

Absorbance: The Olis DB 620 UV/Vis, NIR Spectrophotometer

The Olis DB 620 UV/Vis [NIR] Spectrophotometer is our dual beam absorbance spectrophotometer, optimized for microsecond kinetics and so stable and noise-free that it is suitable for lengthy thermal melts and equilibrium studies, too.

This modern digital optical bench provides high accuracy, high performance true dual beam data at rates to 50 ns with and without associated scanning. With one millisecond of collection time, 1000 data points are fitted to a straight line to return RMS noise at 250 nm of 0.0014 AU; with 1 second collection time, RMS noise lowers to 0.00016 AU. Scanning between these high speed fixed wavelength readings results in extremely low noise spectra.

Designed originally for laser flash photolysis work, this model remains ideal for flash using a laser, flash lamp, pulsed source, or LEDs. By adding thermal regulation hardware (a water bath or Peltier cell holders), the Olis DM 620 can be used for automated thermal melts. Shutters can be positioned anywhere in the optical train for protecting photolabile samples during scanning or fixed wavelength readings.

All high-speed optics and detection hardware makes the Olis DB 620 a superb choice for stopped-flow spectroscopy (page 10).

A second detector at 90 degrees to the sample is sufficient for fluorescence stopped-flow as well as absorbance. Or, by adding an emission monochromator, one produces the Olis DM 245 (page 5) from the Olis DB 620. Likewise, replacing the compact

sample chamber of the Olis DB 620 with the Olis CD Module, produces the Olis DSM 20 CD (page 6-8).

Fluorescence: The Olis DM 245 Spectrofluorimeter

The Olis DM 245 spectrophotometer is the answer to “What is today’s best research spectrofluorimeter for steady-state and kinetic studies?”

With a Hummingbird double monochromator outputting a homogeneous excitation beam of arbitrary bandwidth, one has high resolution, low stray light excitation. With a single grating monochromator on the excitation side, one obtains the maximum emission signal.

Our 150-watt xenon arc lamp in a specialized elliptical mirrored housing outputs the intensity of a typical 450-watt xenon arc. A high sensitivity photon counter or a high-speed photomultiplier tube is used for detection. Arbitrary amounts of signal averaging are possible with both detectors. The photon counter, with higher sensitivity, responds in 10 milliseconds to 2.5 second intervals; the photomultiplier tube provides for an uninterrupted stream of acquisition, the rate of which is limited only by the 20 MHz A/D card or user-supplied digital oscilloscope and available memory.

Spectral ranges captured by the detectors is 210-650 nm or 300-850 nm with the photon counter, approximately 200-800 nm with the photomultiplier tube, and to 2500 nm with available InGaAs detectors.

Olis software lets you scan the monochromators independently or in synchrony, so that scanning excitation, fixed wavelength excitation, scanning emission, fixed wavelength emission, and synchronous scanning of emission and excitation are supported.

These same components can be used for light scatter or luminescence measurements, as well as single or dual beam absorbance data. (Recall, without the emission monochromator, the Olis DM 245 is an Olis DB 620, facing page.)

The standard sample compartment houses a single 1 cm² jacketed cell holder. Alternative cell holders include two, four, six, and ten position units, with water jacketed thermal regulation or Peltier electronic thermal regulation. Polarizers and shutters can be positioned anywhere in the optical train of the fluorimeter to support L-format, T-format, or variable retardance methods¹ of anisotropy measurements.

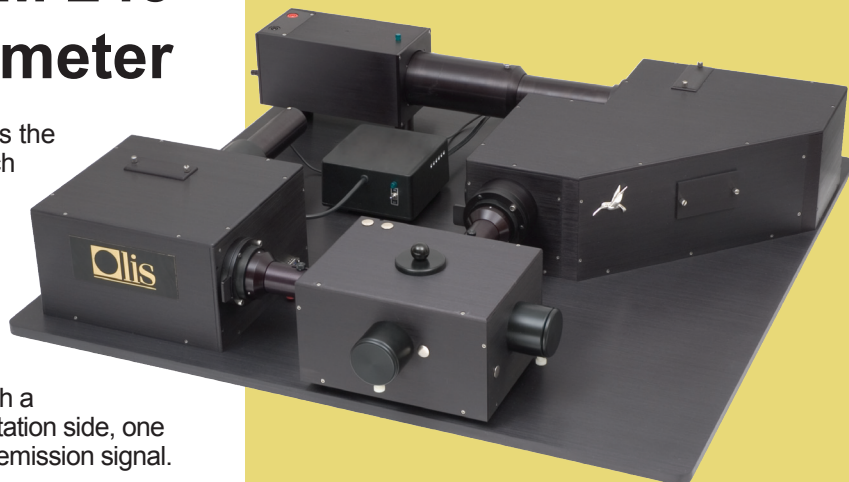

Without the Hummingbird, but with two single grating monochromators, we offer the Olis DM 45.

Alternately, and not shown here, two Hummingbirds can be used, producing the yet-to-be unveiled Olis DM 445.

1. DeSa, Richard. 2005. Device for Enabling Slow and Direct Measurement of Fluorescence Polarization. U.S. Patent 6,970,241 B1, filed August 24, 2004, and issued November 29, 2005.

Circular Dichroism: The Olis DSM 20 CD



The Hummingbird monochromator is used to create the tiniest CD on the market, the Olis DSM 20. A tiny monochromator means modest nitrogen use and non-imposing appearance.

For proteins, peptides, and the other common CD samples, the Hummingbird is fitted with UV blazed gratings and the ozone-producing 150 watt xenon arc lamp, producing useful light from 170-700 nm.

For use outside of the protein region, the Hummingbird will come with visible or NIR blazed gratings and a second order rejection filter; the CD Module will come with NIR optimized detectors (InGaAs, either standard or extended range). CD scanning to 2500 nm is possible with these optics and detectors.

For fluorescence and/or FD CD readings, the Olis DSM 20 CD can be fitted with a detector at right angles to the sample (at port 7, facing page). Scanning emission is added when a second Hummingbird or the smaller single grating monochromator are added (see Olis DM 245 and Olis DM 445, previous page).

Accessories include the Olis USA CD stopped-flow mixing apparatus, a two or four syringe Olis Automatic Titrator (page 11), single or Twin Peltier CD cell holder (3c, facing page), and the DeSa 1.4 Tesla magnet for MCD (shown), among others.

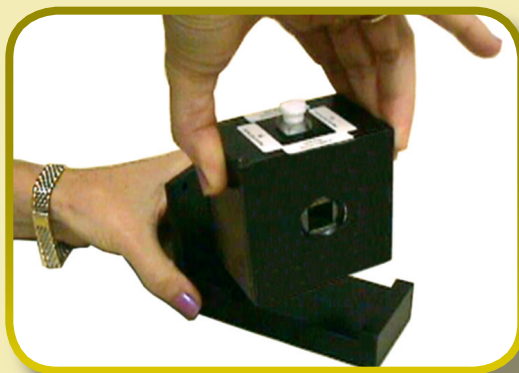

1.4 Tesla DeSa Magnet

With this 1.9 kg magnet, one can economically and easily turn an ordinary Olis DSM 20 CD into a MCD powerful enough for many MCD studies, including reverse field measurements, and inexpensive enough for pedagogical labs.

Physical Layout of CD Module

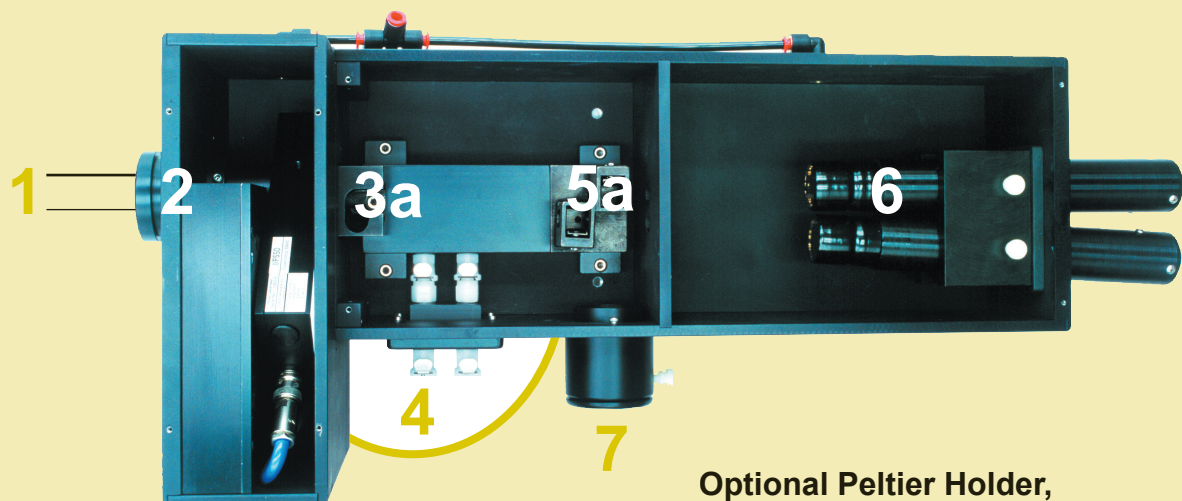

Optional Peltier Holder, replacing 3a and 5a (and 4)

3b

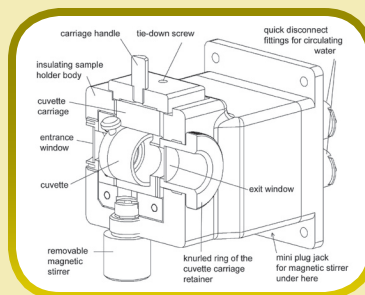

5b



- 1 Incoming beam from monochromator.
- 2 Magnesium fluoride polarizer/beam splitter splits the light beam (1) into two linearly polarized beams each orthogonal to the other. Angle of divergence can be as small as 1° and as wide as 5°; standard divergence is 3° putting beams of light 3.5 mm apart at the center of the CD sample position (3). Also, the 50 kHz Hinds PEM-90, which modulates between RCP and LCP 50 times per millisecond.
- 3 Under most circumstances, the CD sample will be positioned near the PEM and beam splitter. The sample holder will be the default jacketed model, compatible with cylindrical and rectangular cuvettes (3a) or the optional QNW TLC-250 Peltier model (3b).
- 4 Water lines to cuvettes 3a & 5a, so that a digital or manual temperature can be achieved using a water bath.
- 5 Pair of 1 cm² rectangular cell holders for dual beam absorbance, single beam fluorescence, and running two CD samples simultaneously. Default pair, 5a, is water jacketed and is provided with 3a. Optional Peltier holder, 5b, is provided in addition to or instead of 3b.
- 6 Two detectors optimized for the desired UV/Vis or Vis/NIR region (see pages 26 and 27). Each detector has its own amplifier circuitry and its own high precision A/D converter.
- 7 Port for optional detection of fluorescence or FDCD, or for flash lamp to photolyze sample, in position 5.

- ▶ The CD detection is the “Digital Subtractive Method” (“DSM”) of acquiring absolute CD. “DSM” detection is the only means of collecting (not calculating) circular dichroism (“CD”). The answer can only be correct!
- ▶ The CD spectrophotometer requires no calibration. Acquisition by definition is superior to calculation after (fallible) calibration.
- ▶ The CD is linear to 10,000 millidegrees, opening up use with a huge choice of sample concentrations.
- ▶ The CD has zero drift. Experiments can be indefinitely long and the last scan will be as correct as the first.
- ▶ Use of the CD spectrophotometer does not require any prior knowledge about the sample by the operator. There are no amplitude, sensitivity, or time constant settings to make prior to scanning the sample.

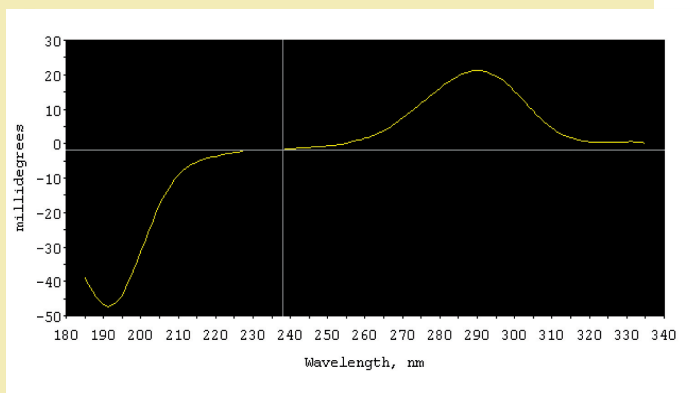

- ▶ CD spectrophotometer uses 100% of the light from the lamp rather than the 50% used by a single beam CD spectrometer. More light is always good.
- ▶ The CD supports variable data collection rates, so that the minimum length of time will be used to scan a spectrum, saving time, nitrogen, and the need for repetitive scanning.

An Olis DSM CD Should Be Your Next CD Because:

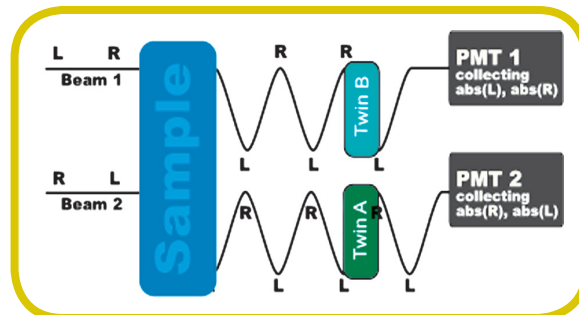

- ▶ Two CD samples can be scanned simultaneously, which is used mainly for long thermal melts; samples are in a twin CD/2 rectangular cell holder.
- ▶ Kinetic CD acquisition supports up to 2,000 readings per second.
- ▶ The CD spectrophotometer sample compartment includes up to three jacketed cuvette holders, one for cylindrical and rectangular dual beam CD cuvette use and two for 1 cm² and microvolume single beam CD and dual beam absorbance cuvette use. Alternatively, and at higher cost, the CD spectrophotometer sample compartment can be fitted with 1, 2, 3, or 6 thermoelectric heating/cooling Peltier cells for electronic temperature ramping.
- ▶ There are three independent nitrogen regulator settings for the monochromator, sample compartment, and lamp housing, allowing for most judicious nitrogen use.
- ▶ The CD spectrophotometer is delivered with software for collecting and analyzing data as a function of wavelength, time, concentration, and/ or temperature (3D global analysis, as well as 2D fits).

Other Hardware Involved



1-3 Tower Pentium 2.8 and 17" LCD (1) or laptop (not shown), lamp power supply (2), and Ollis electronic control box (3).

4 Trigger box for stopped-flow option

5-7 Cooling boxes for the Peltier cell holders (5), the 450 watt lamp and Peltier (6), the 150 watt lamp (7)

8 Nitrogen purging regulator (8), providing independent channels for lamp housing, monochromator, and sample compartment. Liquid N² tank recommended with fast flow release.

These ancillary components are provided with all Hummingbird series spectrophotometers, as appropriate. The stopped-flow box (4) is only included when a stopped-flow is provided. The smaller cooling box (5) will be supplied unless a 450 watt Xenon arc lamp is requested, which uses the larger box (6). Nitrogen purging (8) is required only by the CD model.

Olis USA Stopped-Flow

Mount one of four of the Olis USA stopped-flow mixing units to add millisecond mixing to any Olis Hummingbird system.

The Olis USA stopped-flow will provide much faster mixing and much higher intensity signal than a low cost umbilical cord type mixer. However, Olis software supports use of any device which sends or receives a TTL pulse. One could use an umbilical cord type mixing apparatus with an Olis spectrophotometer without making any A/D or lamp changes.

Decades of experience with all types of stopped-flows¹ prepared us to design our models with features most utilitarian from them all. The traditional Ball-Berger mixer and pneumatic drive systems are used, as is the horizontal orientation of the drive syringes².

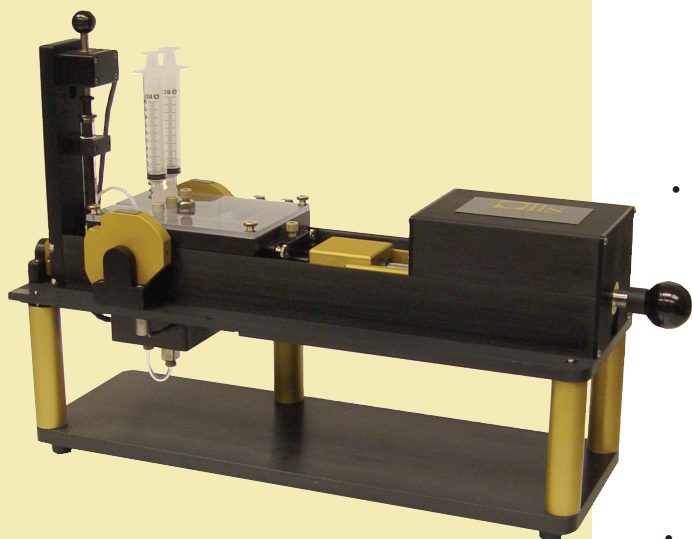

Footnotes

¹ In 1969, Olis founder, Richard J. DeSa, published the first paper on computerized stopped-flow spectroscopy with his postdoctoral advisor, Quentin Gibson. The paper, "A Practical Automatic Data Acquisition System for Stopped-flow Spectrophotometry (Computers and Biomedical Research, 1969, 2:494-505) describes the authors' use of computers to analyze and store fast kinetic data. The "stopped-flow spectrophotometer" is introduced and described in "Rapid Mixing: Stopped Flow," Chapter 6, volume XVI in Methods in Enzymology; this chapter is still the best introduction to the technique we have seen and a "must read" reference for everyone new to stopped-flow mixing. Since its founding in the mid-1970s, Dr. DeSa's company has computerized hundreds of stopped-flows, ranging from homemade models to the most sophisticated commercial version.

² Vertical orientation of these syringes has presumed advantages. In practice, horizontal syringes are easier to work with.

Why the Olis USA Stopped-Flow?

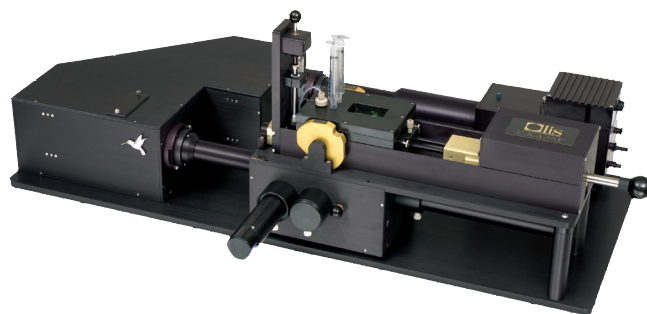

- The stopped-flow uses ceramic valve blocks for durability against all corrosive solutions, temperature ranges, and gas exchange.
- The stopped-flow is fitted with five sensors to provide 100% security against misfiring, premixing, and damage to the hardware and operator. Feedback from these sensors comes from both the trigger box (LED display) and/or Olis control software.
- The stopped-flow provides anaerobic performance with gas purging available in three positions.
 - The stopped-flow has a deadtime of approximately one millisecond.
 - The stopped-flow supports use of syringes from 0.5 to 5 mL so that 1:1 up to 1:11 mixing can be achieved (unit will be delivered with one pair of 2.5 mL syringe unless prior arrangements are made).
- The stopped-flow is useable over a temperature range of 10°C to 100°C.
- The stopped-flow is pneumatically driven for reliable performance, even when solutions of different viscosities are used.
- The stopped-flow is useable with an optional Auxiliary Mixer for preparation of an unstable A + B mixture that will subsequently be one of the reagents used during stopped-flow.
- The stopped-flow mixing mounts easily and correctly with one tool and no alignment or calibration.

Four Syringe Peltier Titrator

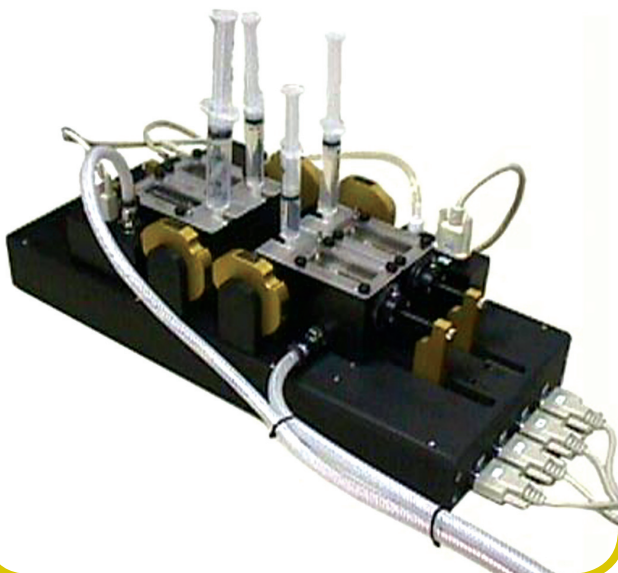

The four syringe model is useful for simple protein + titrant (two syringes), for maintaining sample concentration (3 syringes), for enzyme assay or other complex titration (4 syringes).

Cuvette for Absorbance/Fluorescence Titration



Cuvette for CD Titration



The Olis Titrator's Components

- The novel OLIS computer controlled titrator exclusively provides mixing external to the measuring cuvette, allowing use of cuvettes with any pathlength from 0.1 to 20 mm. Thus, this accessory is equally useful in absorbance, fluorescence, and CD spectroscopy applications.
- The OLIS titrator provides mixing ratios down to 1.0 : 0105 microliter per titration.
- The OLIS titrator uses two, three, or four gas tight syringes in any combination of sizes from 0.1 ml to 10 ml to support a variety of titration and mixing experiments.
- The OLIS titrator provides very effective mixing, even when solutions have very disparate viscosities. Gravity cannot cause or effect mixing, so no tricks are required to deal with heavy solutions 'dropping' in cuvette.
- With the OLIS titrator, aging and/or equilibration occurs out of the measuring beam; the solution is not liable to photolysis.
- The OLIS titrator is controlled via a standard RS-232 port through the OLIS software (or another program when used with other spectrophotometers).
- Use any of the four titrators with any Olis spectrophotometer fitted with the appropriate cuvette holder and cuvette. These titrators allow microliter precision sample preparation into all pathlength cuvettes. Thermal control is possible at the titrator and/or at the measuring cuvette.

Two Syringe Ambient Titrator

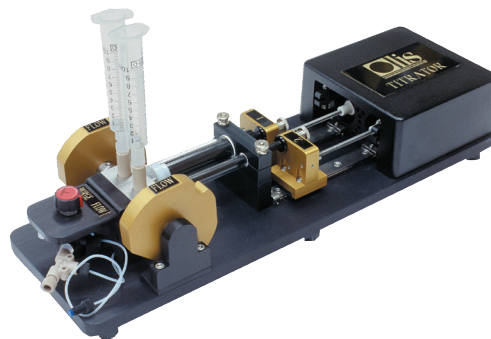

Exploded View of SpectralWorks Screen

Title Bar



Menu Bar

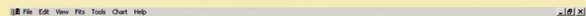

Tool Bar

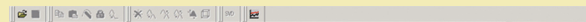

Data Collection Tabs

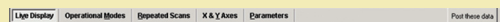

Instrument Settings



Data Display

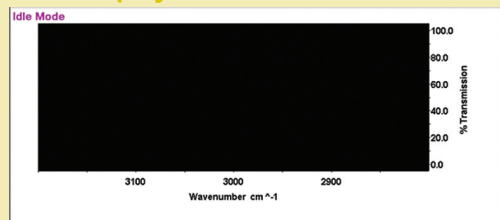

Status Bar

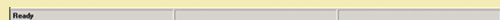

Experiment Window



Properties Window



Olis[®]

SpectralWorks[™]

Every step of setting up the experiment through final storage of the results is done with the Olis SpectralWorks software package.

Through this Windows XP compatible program, one sets the spectral range, scan speed, and accessories to be controlled. Parameters can be changed individually or collectively with easily produced Protocol files.

Raw data from both sample and reference channels can be viewed at any time; processing of these signals is available as abs, D abs, %T, volts, mdeg, or other unit.

A split screen is often employed so that both spectra and kinetics can be viewed side by side; a dynamic slicing option allows viewing of 'scan at time x' as well as 'kinetics at wavelength y.' Within this comprehensive data acquisition/instrument control program is all of the functionality of GlobalWorks, our data analysis program. Here, you will find all data processing algorithms for simple 2D analysis (e.g., smoothing, derivation, peak finder, integration, secondary structure determination) as well as algorithms for fitting kinetic and equilibrium 3D data sets.

Data are saved as Olis binary files; with a right click of the mouse, ASCII, Excel, and JPG files can be produced.

Both the Pentium PC hardware and the Olis SpectralWorks software are included in the purchase price of an Olis spectrophotometer. Laptops are available with some models.

Page from Olis SpectralWorks Manual

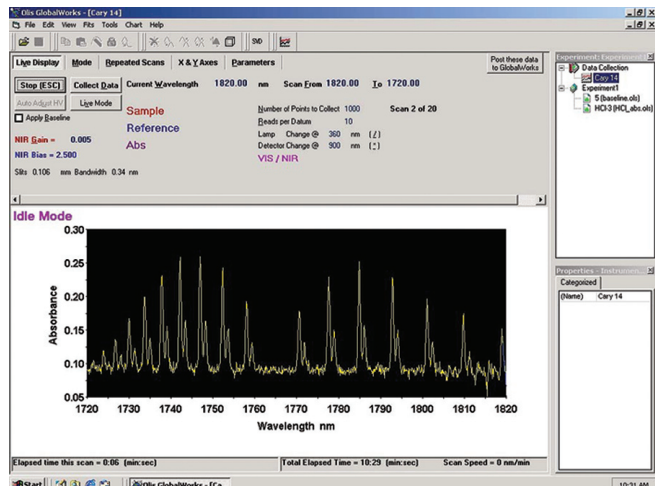

Live Display
Displays current instrument settings and collection of data.

Slits: 0.106 mm Bandwidth: 0.34 nm

SLITWIDTH AND BANDWIDTH

The current slit width and resulting bandwidth are reported here. When **Data Reduction Mode** is set to **Single Beam**, the user can assign these values. Otherwise, slit width is adjusted to compensate for changing light intensities.



LIVE SIGNAL DISPLAY

During data collection and live mode the current sample, references, and absorbances are displayed here. The calculation data will depend on the **Data Reduction Mode** set in the **Operational Modes** tab. Values will be continuously updated when the instrument is in **Live Mode**.

This is an example page from the manual which shows the user interface one interacts with while setting up the instrument for data acquisition; the spectra shown are of benzene vapor acquired on an Olis 17.

Pull-down menus, fill-in-the-blank numbers, and click-on tabs are used on this **Live Display** page. The “Live Display” tab is depressed (notice its slightly lighter color than that of the **Mode**, **Repeated Scans**, **X & Y Axes**, and **Parameter** tabs). Because of this, certain instrument parameter choices are presented to the operator.

Numeric values for “Scan From ____ to ____” are inputted directly. Selection of “Apply Baseline” is done by clicking the box next to the choice. The Parameter tab will allow access to optionally used accessories. And so on.

Boxes to the right of the graph contain file name and file specification information. (See previous page for an exploded view of this screen.)

Current Wavelength 1820.00 nm Sc

CURRENT WAVELENGTH

The current wavelength is displayed here and will update during a scan. The wavelength range is 185-2600 nm and is changed by clicking on the value. *The keystroke shortcut for changing Current Wavelength is **W**.*

Scan From 1820.00 Io 1720.00

SCAN RANGE

Starting and ending scan wavelengths are displayed and entered here. The acceptable wavelength range is 185-2600 nm, and it is generally advisable to scan down from the higher wavelength. *The keystroke shortcuts for entering the starting and ending wavelengths are **F** and **T** respectively.*

Data Processing with Olis SpectralWorks Software

Olis SpectralWorks software includes a long list of useful data processes for single datasets including:

- Apply Constant
- Average Scans Within Dataset
- Average Points
- Convert Volts to Absorbance
- Correct Fluorescence
- Convert CD Units
- Dilution Correction
- Derivative
- Digital Filter
- Fourier Transform
- Integration
- Interpolate
- Normalize
- Peak Finder
- RC Filter
- Reverse X Axis Data Array
- Reverse Y Axis Data Array
- Reverse Axes Data Array
- Swap Axes
- Synthesize New Dataset
- Trim Points
- Take Reciprocal
- CDSSTR
- CONTINLL
- SELCON3
- Inverse Spectrum

Olis SpectralWorks software also includes data processes for working with multiple datasets:

- Add Selected Datasets
- Subtract Selected Datasets
- Average Selected Datasets
- Multiply Selected Datasets
- Apply Constant
- Normalize
- Concatenate
- Anisotropy
- Polarization
- Corrected Scans
- Build 3D Dataset from 2D



All Olis Instruments operate with extremely similar versions of Olis SpectralWorks™ software

This composite image shows the spectrum (upper left), the data processing choices (lower left), selection of 1-4 order derivative (upper right), and the final screen with the second derivative calculated and plotted.

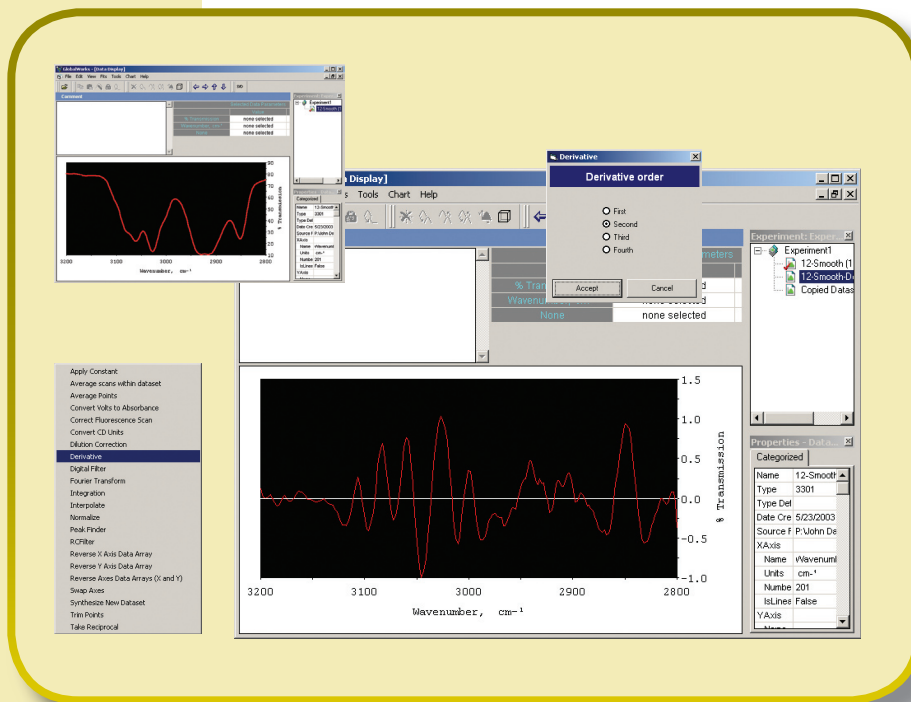

Unique Attributes of all OLIS Hummingbird Spectrophotometers

- A high efficiency subtractive double grating monochromator, which produces a brilliant homogeneous output beam. There is zero spectral dispersion in the measuring beam(s), regardless of the bandwidth.

- Optical surfaces in the monochromator include large 40 x 45 mm holographically blazed with the user-specified number of lines per millimeter and blaze wavelength, easily exchangeable between measurements for optimization within the UV, Visible, and NIR spectral ranges (see page 2 for five most common choices).

- For UV and visible ranges, the spectrophotometer uses two photomultiplier tubes (PMTs) for absorbance, CD, FDCD, and/or kinetic fluorescence detection. For NIR, two fast response InGaAs detectors support detection to 1650 nm or 2500 nm. a photon counting detector for high sensitivity emission work.

- The spectrophotometer's sample compartment comes with one, two, three, four, or more cuvette holders, jacketed or Peltier. Or, the sample compartment houses a stopped-flow mixing system (page 10), an easily reversed permanent magnet, variable angle thin film holder, and/or other required sample holder(s).

- The electronics are external to the optical bench, ensuring that diagnosis and repair are as simple and economical as possible (page 9).

- The bandwidth is user-selectable with easily interchangeable slits or by dialing in the chosen width from an optional multiple slit wheel assembly.

- The spectrophotometer supports microsecond fixed wavelength detection at rates to 20 MHz (2000 points per millisecond) with the kinetic optimization package.

Optical Layout of Hummingbird Subtractive Double-Grating Monochromator

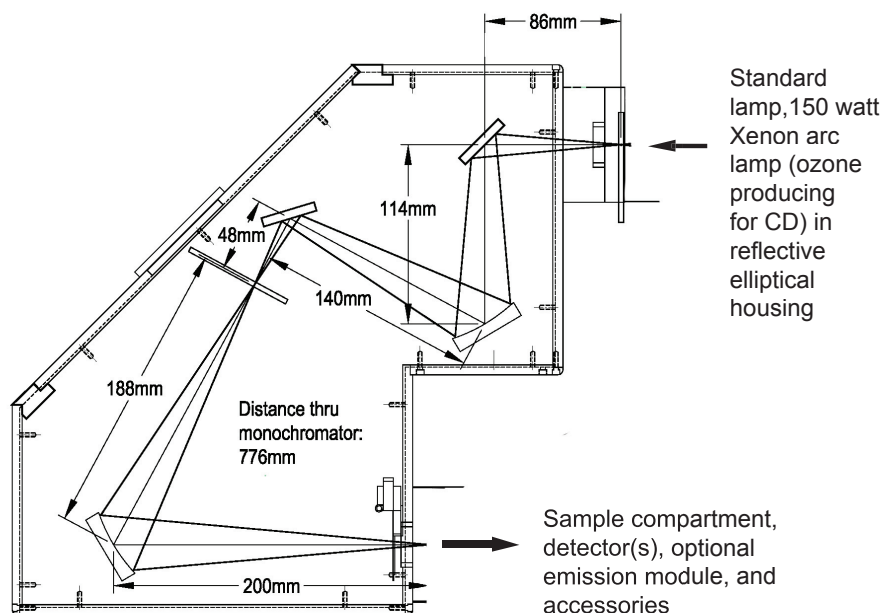

Minimal reflective surfaces and large 40 x 45 mm gratings for very high light throughput

- The spectrophotometer imposes minimal photolysis effects on a sample by shining only monochromatic light during scanning. Shutters can be added anywhere within optical train.

- The spectrophotometer will support luminescence, fluorescence emission and excitation, anisotropy, polarization of fluorescence, CD, LD, ORD, and variations on a theme thereof, when the appropriate modules are used.

- Olis titrator can be added for simple protein and denaturant or complex enzyme assay preparations (page 11).

- On-site visits for calibration and alignment are not required, since the instrument uses no calibration. On-site visits for wavelength adjustment are not required, since the instrument is optically aligned in the factory and will not come out of alignment unless something breaks.

Putting it All Together...



Computer, LCD, electronics, power supply, and lamp cooling box can be oriented as shown here, spanning a comfortable 1.5 meter range, or these components can be mounted above or below bench level. **The instruments themselves rarely span more than 3 feet!**



For more information on this and other Olis products:

- Visit **www.olisweb.com**
- Write **sales@olisweb.com**
- Call **1-800-852-3504** in the US & Canada
1-706-353-6547 worldwide
- Tour **On-Line Instrument Systems, Inc.**
130 Conway Drive, Suites A, B & C
Bogart, GA 30622